



# Powertrain 2020

## The Li-Ion Battery Value Chain – Trends and implications

**Roland Berger**  
Strategy Consultants

August 2011

*This presentation has been compiled for the exclusive, internal use by our client. Within the framework of the engagement, Roland Berger Strategy Consultants ("RBSC") will act solely in the interest of the client. Property rights in favor of third parties will not be constituted and no protective effect shall arise for the benefit of third parties.*

***The presentation (or excerpts of it) shall be treated confidentially and may not be passed on and/or may not be made available to third parties without prior written consent from RBSC. It is not complete without the underlying detail analyses and the oral presentation.***

*RBSC does not assume any responsibility for the completeness and accuracy of any documents and information made available to RBSC in the course of the project. RBSC assumes that the data and documents provided are complete, comprehensive and that the contents are truthful and exact; a detailed examination has only been conducted by RBSC if stated so in the presentation.*

*The decision over the use, the evaluation of the applicability and the use of the presentation by RBSC are the sole responsibility of the client. The content and scope of the presentation is exclusively at the discretion of RBSC.*

*RBSC shall be liable for damages due to failure to comply with its contractual or other obligations where damage is caused intentionally or by gross negligence by its legal representatives, managers or vicarious agents. In the event of slight negligence, RBSC shall be liable only if it is in breach of its material contractual obligations. Any liability for damage arising from injury to life, body or health shall remain unaffected.*

# Agenda

**A**

## **MARKET DEVELOPMENT:**

We expect that by 2020 xEVs sales volume can capture up to 8% .. 10% of global sales, provided battery costs come down

---

**B**

## **CURRENT VALUE CHAIN:**

Cell manufacturing and processing of active materials represent major parts of current costs – value chain today dominated by Asian players

---

**C**

## **BATTERY COST AND VALUE CHAIN DEVELOPMENT:**

With battery costs decreasing down to 250 USD/kWh in 2020, the value chain is expected to consolidate and to develop a clearer tiered structure

---

**D**

## **IMPLICATIONS:**

The Lilon-battery value chain will change dramatically, automotive companies need to reflect these dynamics in products, partnering strategies and processes

We expect that by 2020 xEVs sales volume can capture up to 8% .. 10% of global sales, provided battery costs come down

Share of powertrain technologies in major markets in 2020 – High scenario [%]

**WESTERN EUROPE**

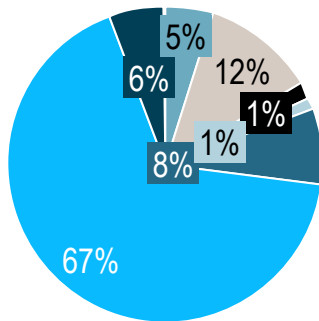

**NORTH AMERICA**

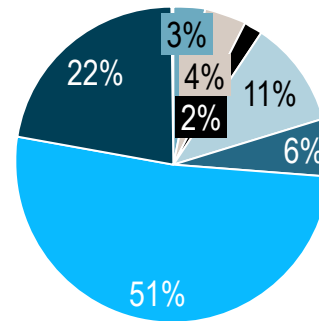

**JAPAN**

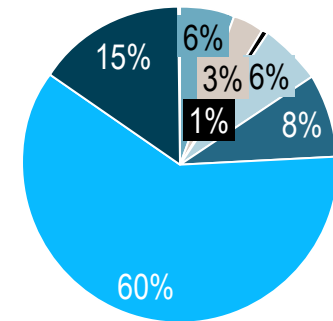

**KOREA**

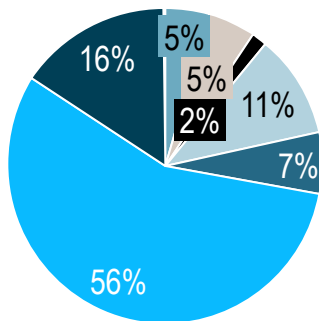

**CHINA**

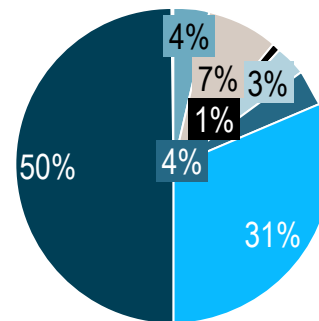

**ROW**

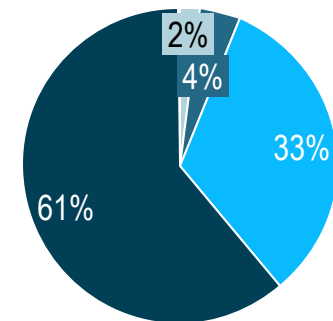

EV PHEV serial PHEV parallel Full hybrid Mild hybrid Micro ICE

# Agenda

## **A MARKET DEVELOPMENT:**

We expect that by 2020 xEVs sales volume can capture up to 8% .. 10% of global sales, provided battery costs come down

---

## **B CURRENT VALUE CHAIN:**

Cell manufacturing and processing of active materials represent major parts of current costs – value chain today dominated by Asian players

---

## **C BATTERY COST AND VALUE CHAIN DEVELOPMENT:**

With battery costs decreasing down to 250 USD/kWh in 2020, the value chain is expected to consolidate and to develop a clearer tiered structure

---

## **D IMPLICATIONS:**

The Lilon-battery value chain will change dramatically, automotive companies need to reflect these dynamics in products, partnering strategies and processes

# To understand cost development the industry structure and future trends need to be understood

## Li-Ion battery supply chain overview

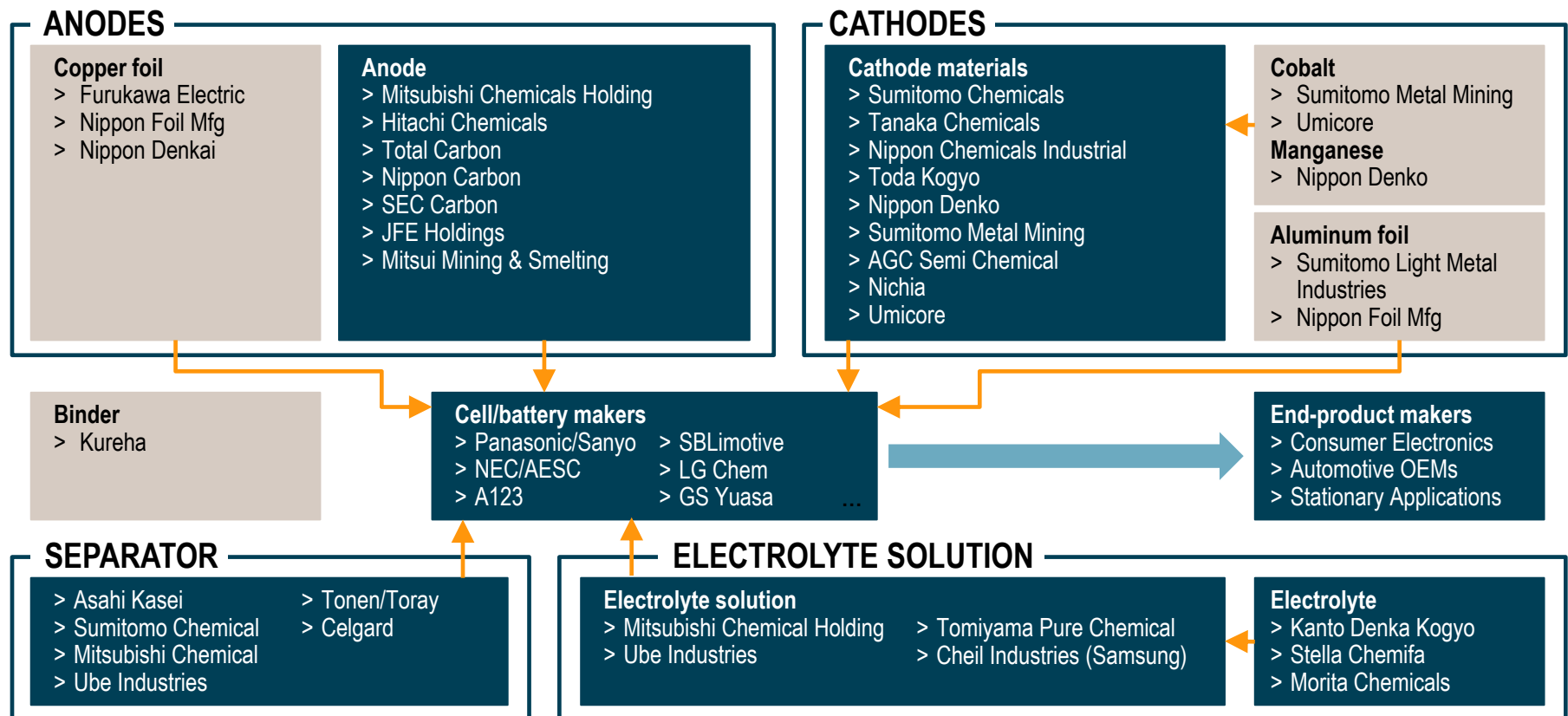

We use a realistic high-energy reference battery for our unique cost analysis covering the complete value chain

Reference battery module used in analysis

**BATTERY MODULE DESIGN**

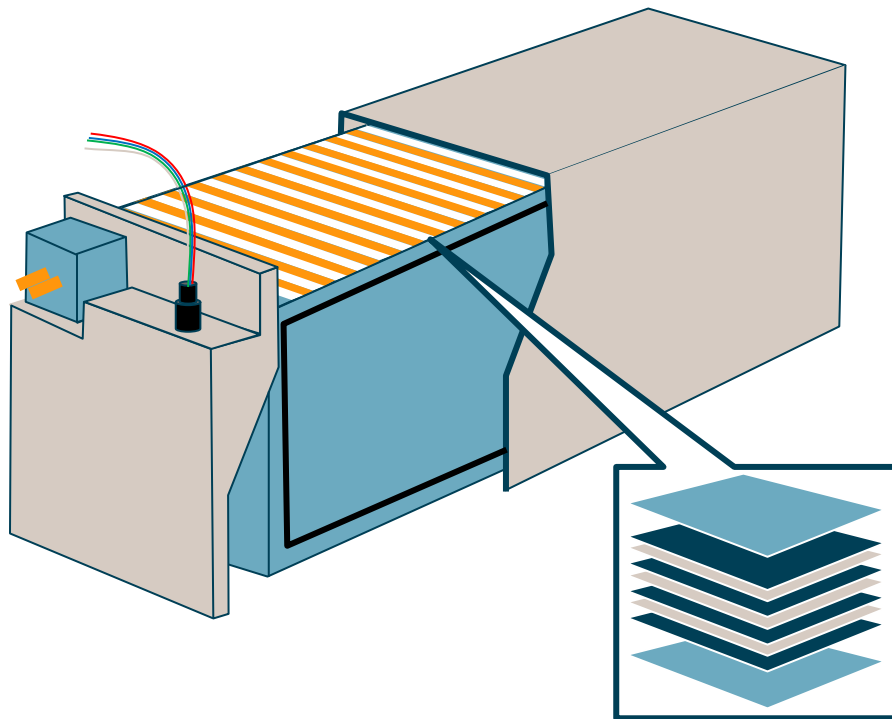

**MAIN SPECIFICATIONS**

- > 266 V/ 20 kWh battery
- > 2 parallel strings with 6 modules in series for each string; (12 modules in total) = 20 kWh
- > Battery module: 44 V/38 Ah = 1.67 kWh
- > Module weight: 13 kg
- > Total battery weight with BMS etc.: 176 kg
- > Integrated liquid cooling with heat conducting plates between cells
- > Integrated module controller, monitoring each cell

# Raw materials and processing account for around 40% of cell costs – High lever for future cost reduction efforts

## Value chain EV battery of ternary mix (NMC), current costs

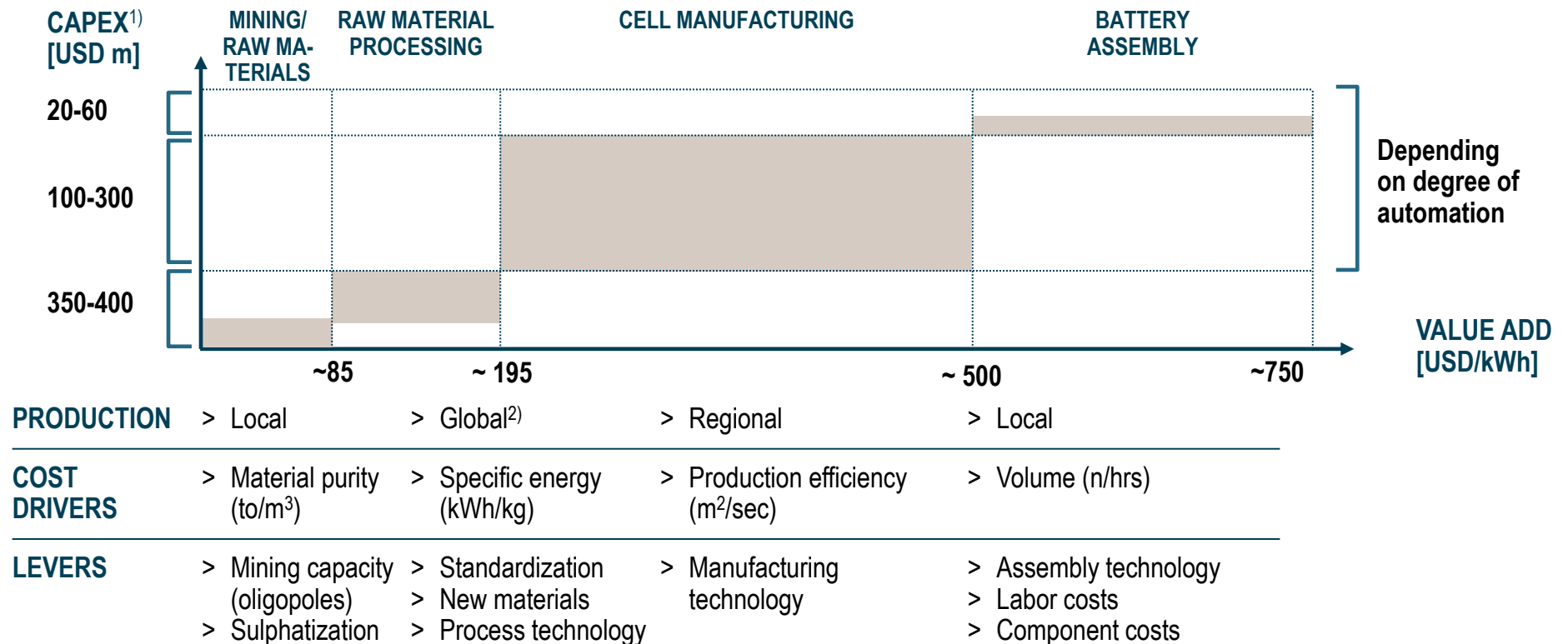

1) Necessary invest for 100 k EV-equivalents (20 kWh) 2) Electrolyte solutions will be produced in region, electrolytes (LiPF<sub>6</sub>) can be produced in a single location for global market

# Co and Ni prices are expected to decrease as capacity is expected to double – Positive effect on cathode material cost

Expected raw material price development 2010-2015 (2010 = 100%)

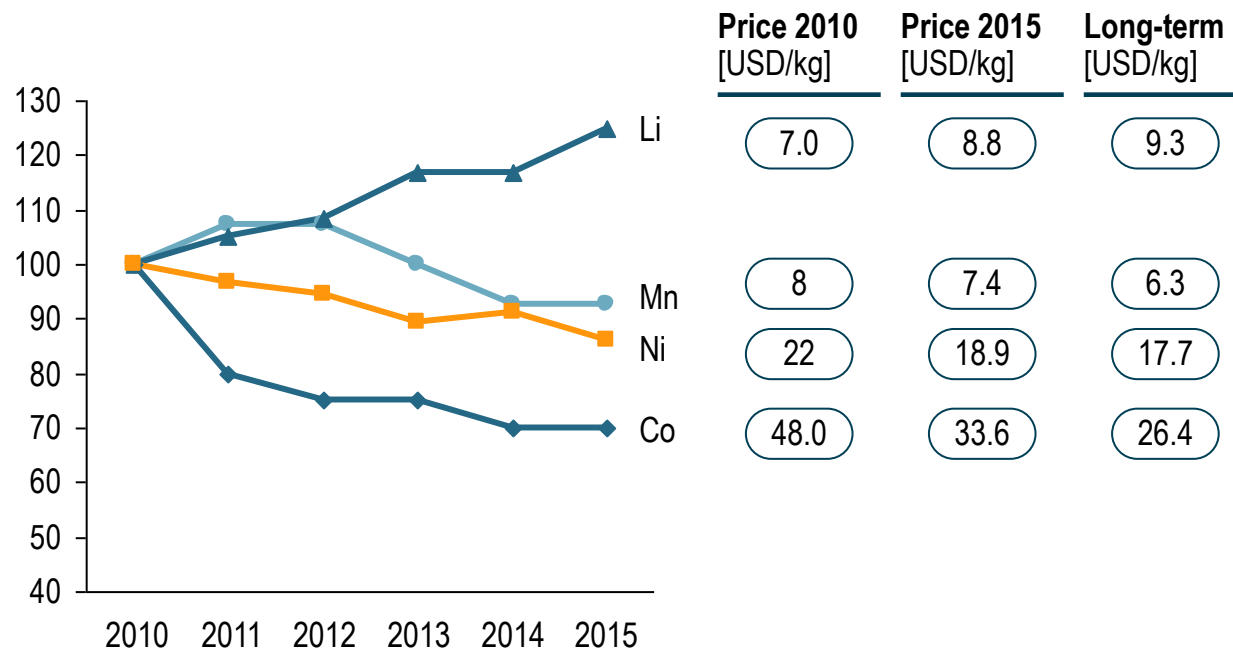

## COMMENTS

- > Increasing **nickel capacities**, production of cobalt as a by-product
- > **Cobalt capacity** expected to **double** by 2015
- > **Lithium price** expected to **increase** until 2015, as only limited capacities built up yet
- > **Price premiums for sulphatization** processes (esp. for manganese) **expected to stay high**

**Li:** LiCO<sub>3</sub> with 19% Li content  
**Mn:** High grade (44%) content

**Ni:** 99.8% Ni content (LME)  
**Co:** 99.3% Co content (LME)

# While Top-3 companies share 60-80% of the market, moderate entry barriers result in new players with rise of Automotive LiBs

## Market entry barriers for battery materials

Market entry barriers	Cathode	Anode	Separator	Electrolyte
Investment need				<sup>1)</sup>
Product know-how				
Production know-how				
Customer relationship				
Access to raw materials <sup>2)</sup>				
<b>New entrants (recent examples)</b>	> BASF > Sumitomo Chem.	> Timcal	> Mitsubishi Chem. > Mitsui Mining > Idemitsu Kosan	> Idemitsu Kosan > Central Glass

Very high   Medium   Low

1) High for LiPF<sub>6</sub> (precursor material)   2) Access to mining capacities (esp. Ni, Co, Mn)

# The four analyzed materials account for 75% of cell material costs – Overall approx. 30% of today's total cell cost

## Importance of different materials in cell battery cost structure

**Battery cell cost breakdown, 2010<sup>1)</sup>**

Total cost: approx. USD 500/kWh

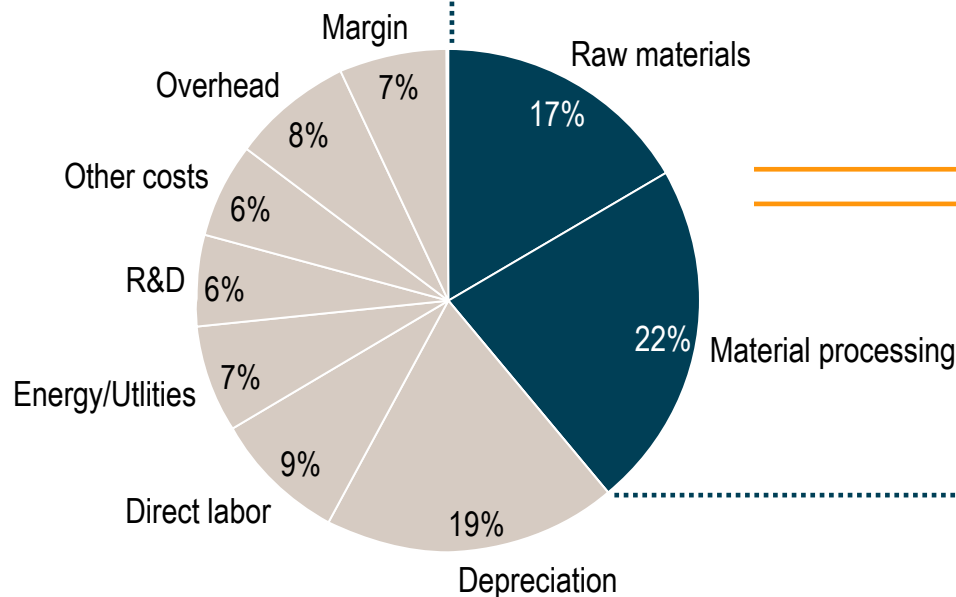

**Material cost split, 2010<sup>1)</sup>**

~USD 195/kWh

~75%  
(approx. 30% of total cell costs)

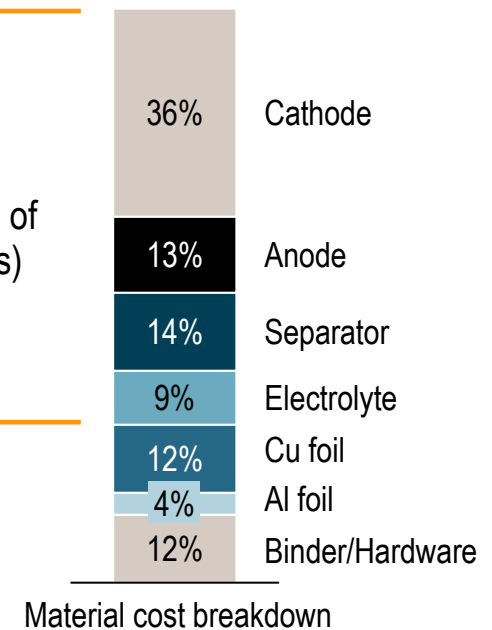

1) Approximate values for ternary mixture (NMC), depend on the chemistry and quality, excl. module/pack components (connectors, housing, BMS, cooling module)

# For materials, price pressure through overcapacities is not expected, as announced capacity build-up is below forecasted demand

## Overview demand vs. cell capacity vs. material capacity<sup>1)2)</sup>

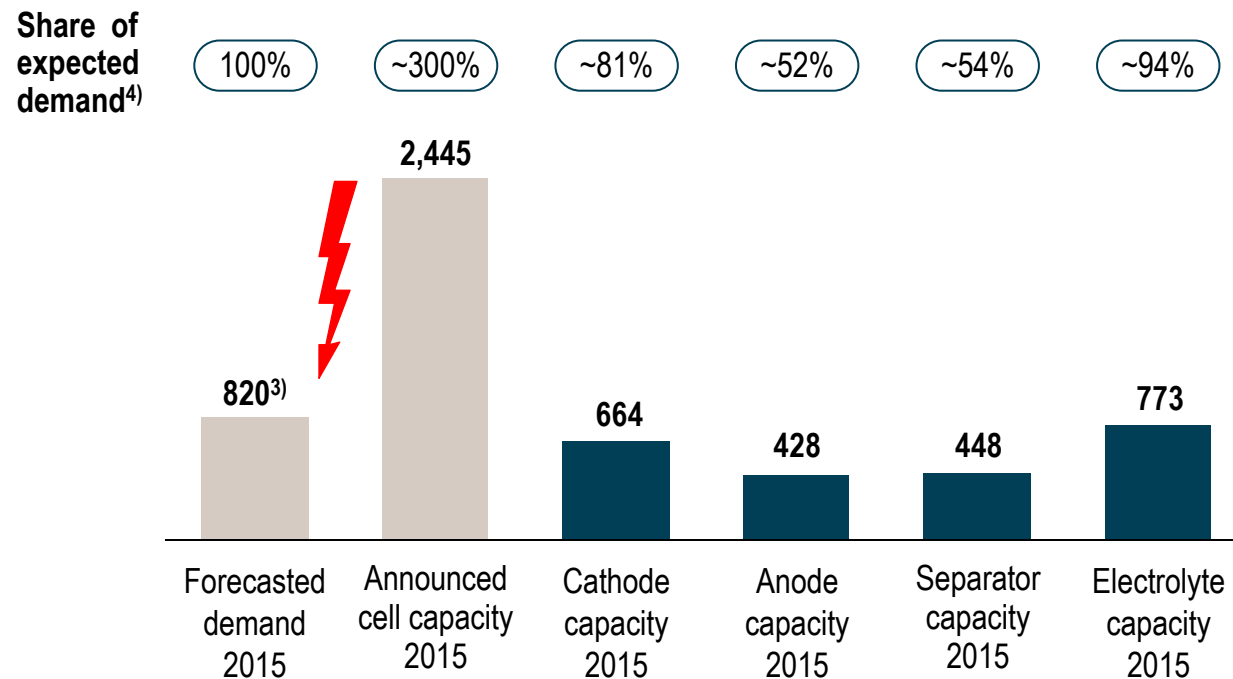

### COMMENTS

- > Li-Ion automotive related materials **capacities are lacking behind** the aggressive capacity increase of cell manufacturers, **especially anode and separator materials**
- > Price reductions in materials therefore not expected to be driven by emerging overcapacities
- > Demand from **consumer electronics** (~2.3 m EV equivalents in 2015) **not shown** on this chart

1) In '000 EV equivalents, 1 EV equivalent 20 kWh, for other assumptions please refer to p. 13

2) Capacity projections include announced plans by manufacturers, might not be exhaustive

3) RB high scenario "The future drives electric"

4) In % of forecasted demand from automotive

# The market for the battery material is highly concentrated – Top-3 companies with 60-80% of the market

Market shares in Li-Ion battery raw materials, 2010 (all applications)

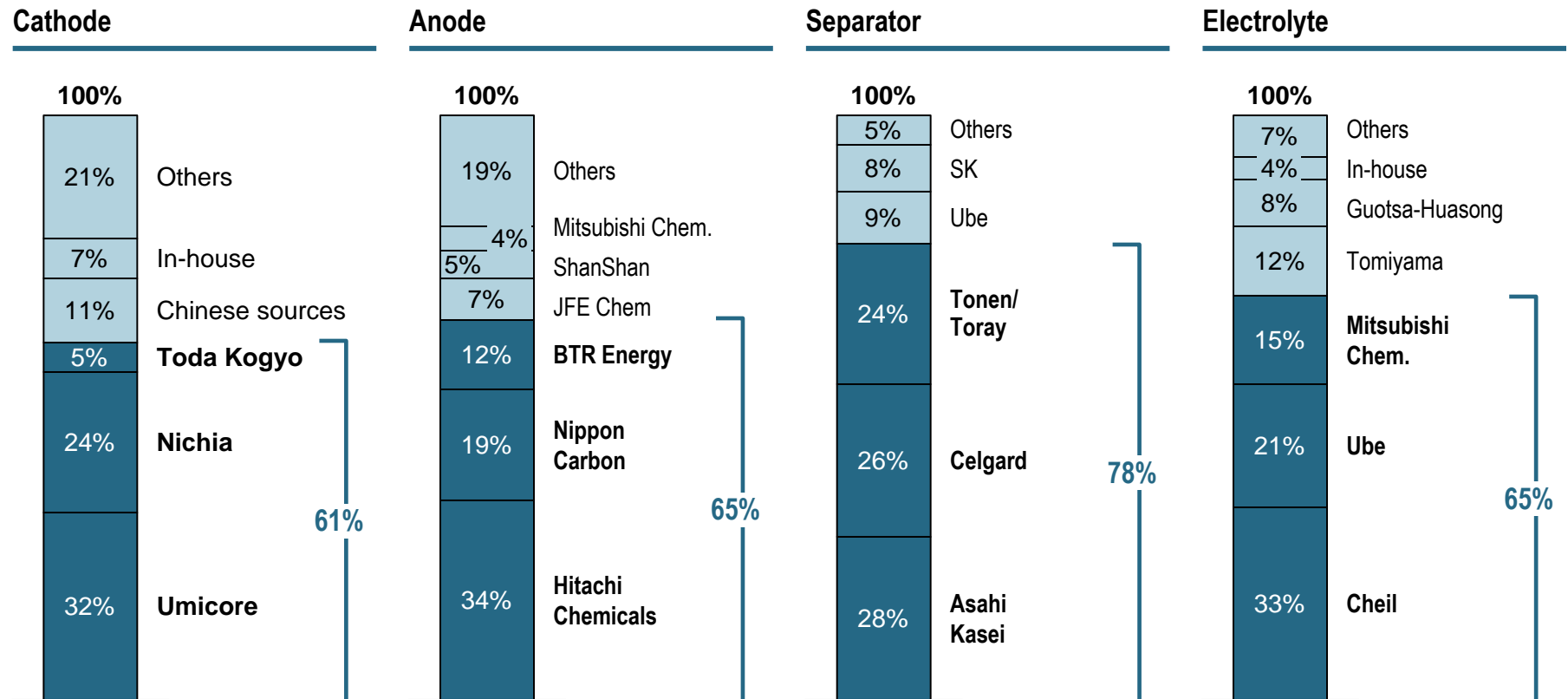

# Scale is one of the major profit drivers in the market – Market leaders usually with highest profitability

## Comparison market share vs. operating profit margin

Market share 2010 [%]

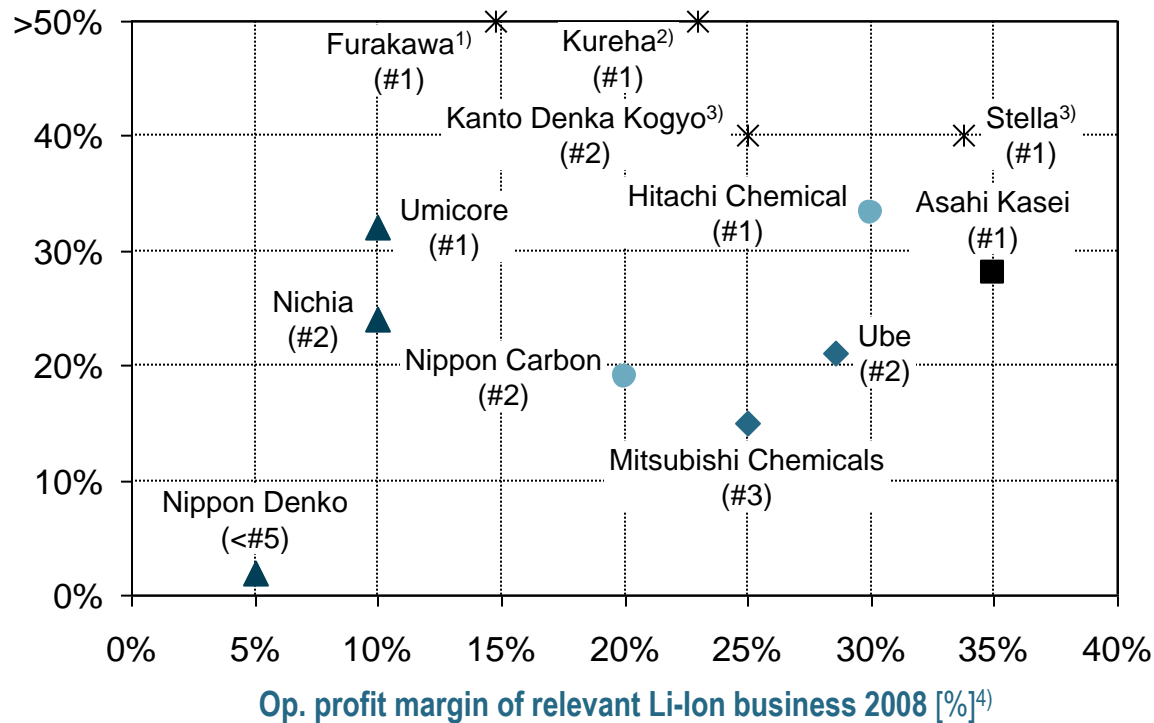

### COMMENTS

- Concentrated market leads to high operating margins due to economies of scale
- High market entry barriers exist for new players, especially for anode and separator material
- Average industry operating profit margins:
  - Cathode materials: 5-10%
  - Anode materials: 15-25%
  - Separators: 25-35%
  - Electrolyte solutions: 25-30%

● Anode materials ▲ Cathode materials ◆ Electrolyte solutions ■ Separators ✕ Other materials (pre- / by-products)

1) Aluminium foil 2) Binders 3) LiPF<sub>6</sub> (electrolytes) 4) Margin estimates per product for 2010 not available

# The cost structure of different materials reflects the know-how areas and major focus areas for cost reduction

Cost structure of different materials (2010)<sup>1)</sup> [USD/kg]

Updated

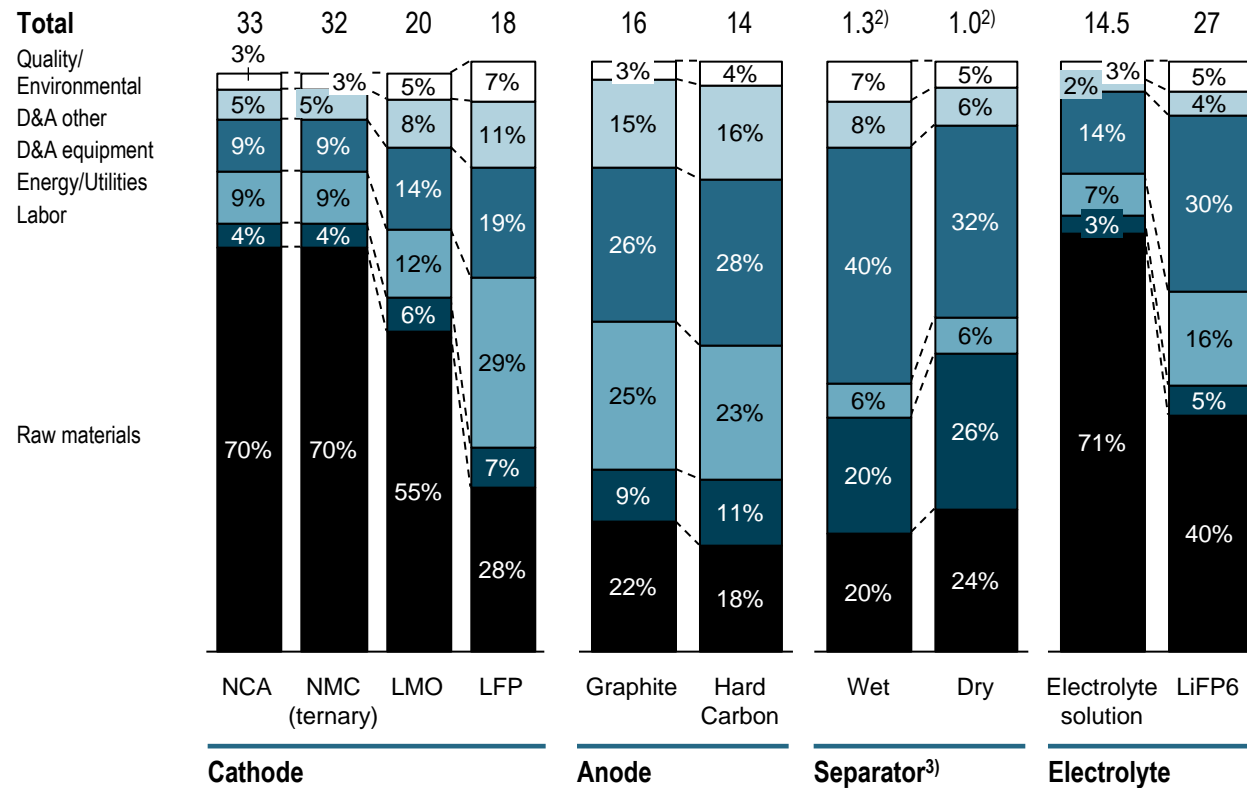

## COMMENTS

- Calculations based on following assumptions:
  - Full capacity utilization
  - Labor cost 100 k USD/year
  - Energy cost 5 US cent/kWh
  - Depreciation equipment 7 years
  - Land, building 10 years
- Costs are based on production in US (labor costs, energy costs per kWh, environmental costs etc.)
- R&D and overhead costs are excluded

1) For typical battery grade materials, excludes R&D and overhead costs 2) In USD per m<sup>2</sup> 3) Raw material cost in separators include subcontracting

Overall, the material prices are expected to fall by 10%..15% in the medium-term (without changes in composition or energy density)

Expected medium-term (2014/15) material price<sup>1)</sup> development, estimates [USD/kWh]

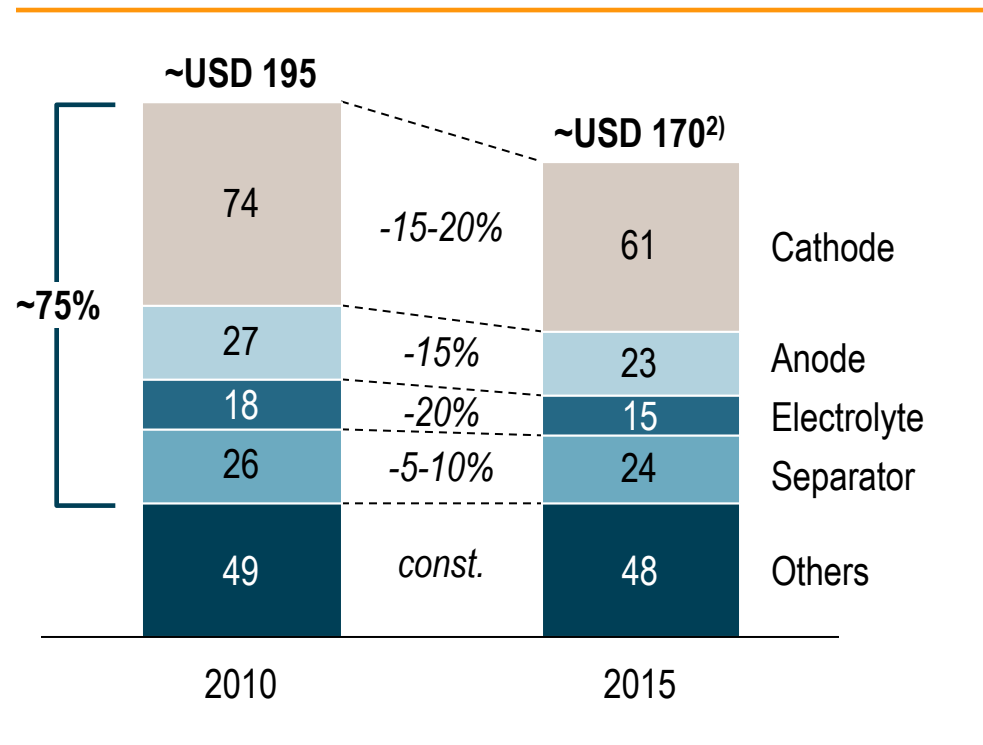

- > Largest contribution to the cost reduction from
  - Cathode due to decreasing raw material prices (Co, Ni) and intense competition
  - Anode due to commoditization
  - Electrolyte due to increasing competition (decreasing margins)
- > Calculation assumes usage of same technologies and material compositions, and other material costs staying constant (binder, Cu/Al collector, housing)
- > Further positive impact on the cell cost expected through new materials, increasing density of the materials

1) Approximate values for NCM cathode (ternary mix) and natural graphite anode, excludes potential improvements in production processes (investments as in 2010)

2) Overall, approx. 15% price decrease expected (incl.others/cell hardware)

# Cell manufacturing can be roughly divided into electrode manufacturing, assembly and electrical formation

## Production steps – Cell manufacturing

### ELECTRODE MANUFACTURING



Slurry mixing

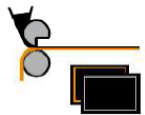

Coating

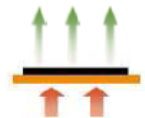

Evaporating

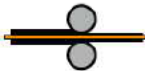

Compressing



Slitting

### ASSEMBLY



Drying



Tab welding



Stacking



Packaging



Filling

### ELECTRICAL FORMATION (SYSTEM DEPENDENT)



Formation



Final Storage and  
Testing

# High automated manufacturing state of the art today – Low automated process only needs approx. 1/3 of total investment

Typical investments for cell capacity – High vs. low automation [USD/kWh]<sup>1)</sup>

## High automated manufacturing process

- > State of the art due to high quality standards in the automotive industry

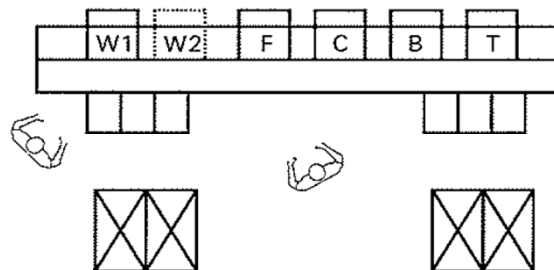

**Invest approx. 300 USD/kWh**

## Low automated manufacturing process

- > Only applied in low cost countries
- > Significant cost saving potential, but high variations in product quality
- > Equipment approx. 30-50% cheaper (low-cost sourcing, lower automation)

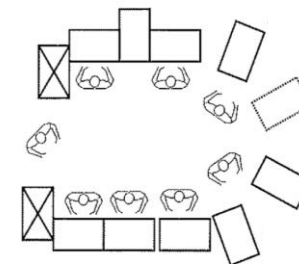

**Invest approx. 100 USD/kWh**

1) Production capacity of 100,000 batteries p.a. @20kWh capacity

# For battery pack assembly, semi-automated processes assumed in Western countries – Approx. 2.5 times more investment required

Investments for battery assembly process [USD/kWh]<sup>1)</sup>

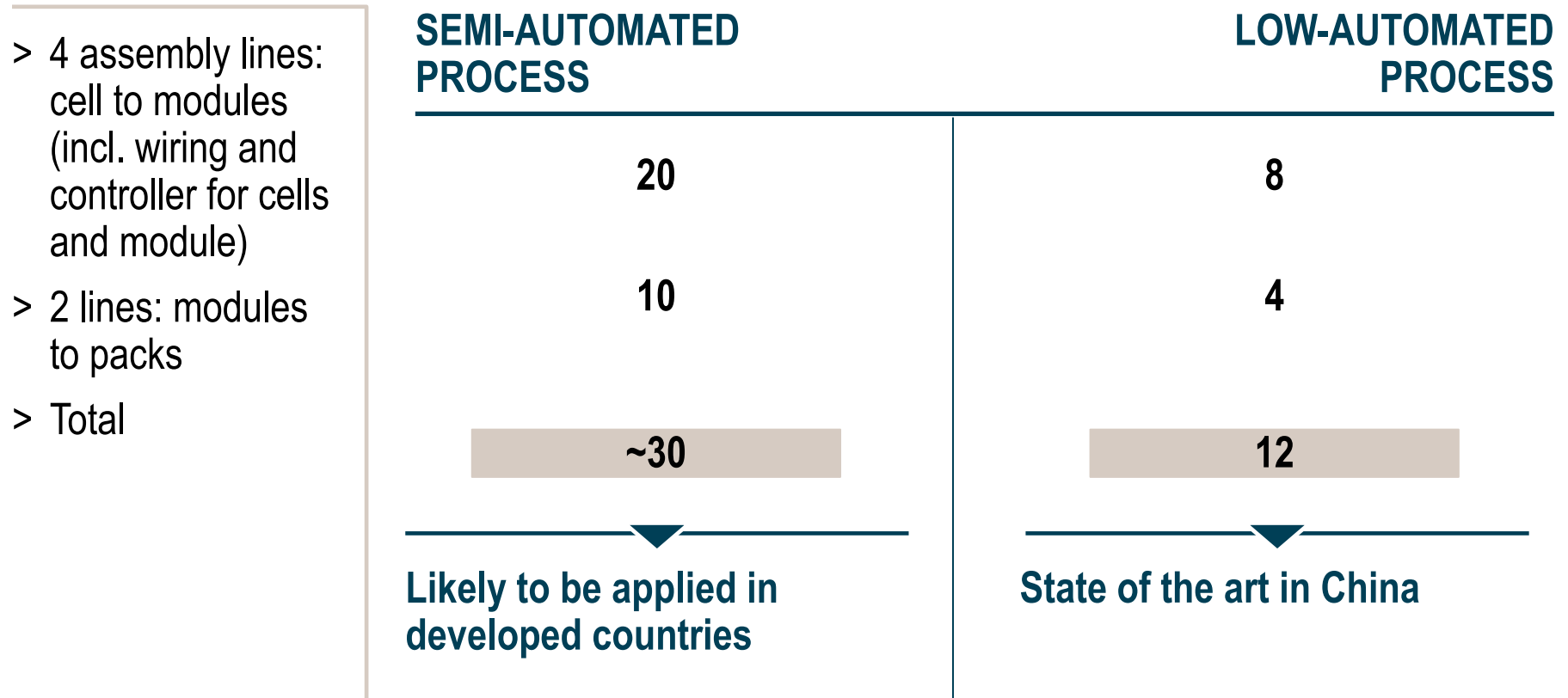

1) Production capacity of 100,000 batteries p.a. @20kWh capacity

# Agenda

- A MARKET DEVELOPMENT:**  
We expect that by 2020 xEVs sales volume can capture up to 8% .. 10% of global sales, provided battery costs come down
- 
- B CURRENT VALUE CHAIN:**  
Cell manufacturing and processing of active materials represent major parts of current costs – value chain today dominated by Asian players
- 
- C BATTERY COST AND VALUE CHAIN DEVELOPMENT:**  
With battery costs decreasing down to 250 USD/kWh in 2020, the value chain is expected to consolidate and to develop a clearer tiered structure
- 
- D IMPLICATIONS:**  
The Lilon-battery value chain will change dramatically, automotive companies need to reflect these dynamics in products, partnering strategies and processes

In 2015, five suppliers will have more than 80% of the LiB market – Chinese small in average, but account together for 8%

Key industry participants in 2015 (Passenger cars and CV)

Expected 2015 global market share<sup>1)</sup> [USD based<sup>2)</sup>]

Σ = USD 8.9 bn

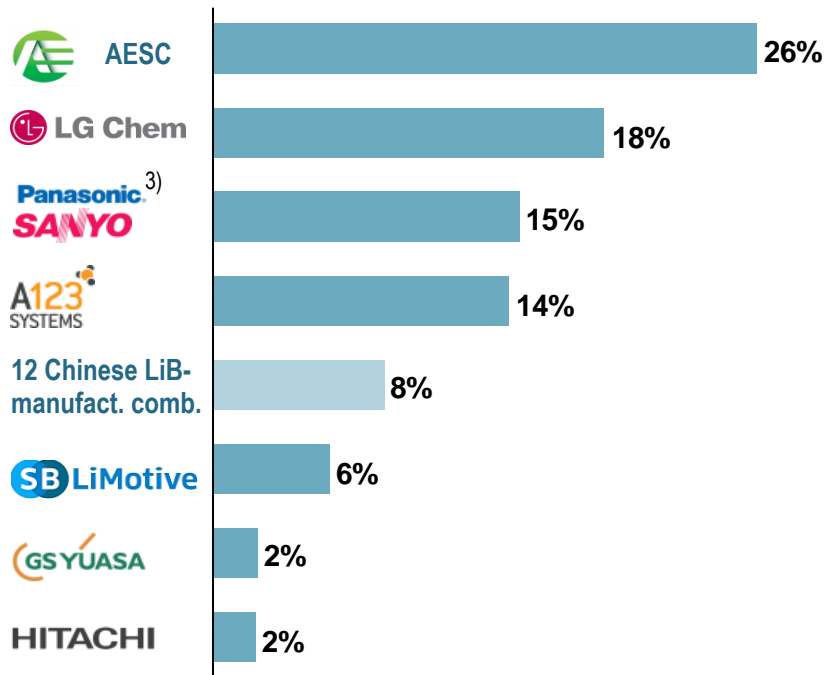

Expected 2015 global market share<sup>1)</sup> [kW, kWh based]

PHEV and EV [kWh]

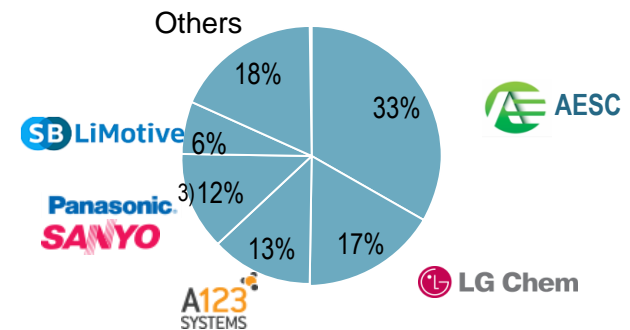

HEV [kW]

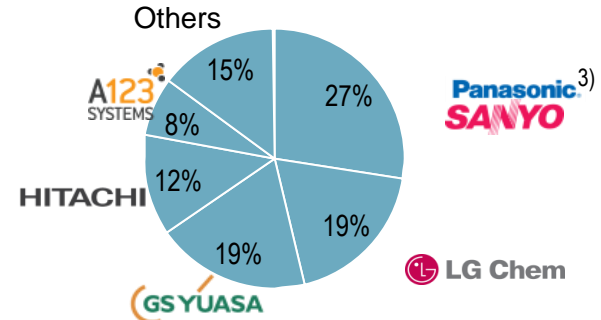

1) Accuracy level: +/- 2%; 2) Market value derived using USD 730/kWh for hybrids, USD 560/kWh for PHEV, and USD 400/kWh for EV in 2015; 3) Includes Primearth's share

# OEM-Supplier relationships are key inputs to determining market share

## Key OEM customers by battery supplier

Battery supplier	OEM customer (contract/development)
 A123 <sup>3)</sup> SYSTEMS	 DAIMLER   NAVISTAR   SMITH   McLaren <sup>2)</sup>  TATA <sup>2)</sup>  VVA <sup>2)</sup>  BRIGHT <sup>2)</sup>
 GS YUASA	 HONDA  MITSUBISHI PSA PEUGEOT CITROËN 
HITACHI	  ISUZU  PACCAR DAIMLER NAVISTAR  FUSO  SUBARU <sup>2)</sup>
 Johnson Controls  SABT <sup>1)</sup>	 DAIMLER  Ford  GAC GROUP  ODYNE  COLLINS  TATA <sup>2)</sup>  FIAT <sup>2)</sup>  CELCELL <sup>2)</sup>
 LG Chem	  HYUNDAI  Ford  RENAULT  VOLVO NAVISTAR PACCAR IVECO DAIMLER <sup>2)</sup>  DAEWOO <sup>2)</sup>
 AESC	 NISSAN  RENAULT
 Primearth EV Energy Co., Ltd  Panasonic  SANYO	 TOYOTA  Ford VOLKSWAGEN  SUZUKI  MAZDA  SUBARU  SCANIA DAIMLER <sup>2)</sup>  ASTON MARTIN <sup>2)</sup>
 SB LiMotive	  FIAT PSA PEUGEOT CITROËN <sup>2)</sup> VOLKSWAGEN  DAIMLER NAVISTAR <sup>2)</sup>

1) Before dissolution, assumes Ford, Daimler, BMW discontinue relationship at end of current programs; 2) Minor relationship; 3) also includes many bus relationships

In light vehicles, typically 2 suppliers are selected strategic partners – share as "2nd source" could change market share by +/- 2%

Key industry participants in 2015 (Light vehicles)

Expected 2015 global market share<sup>1)</sup> [USD based<sup>2)</sup>]

Σ = USD 7.6 bn

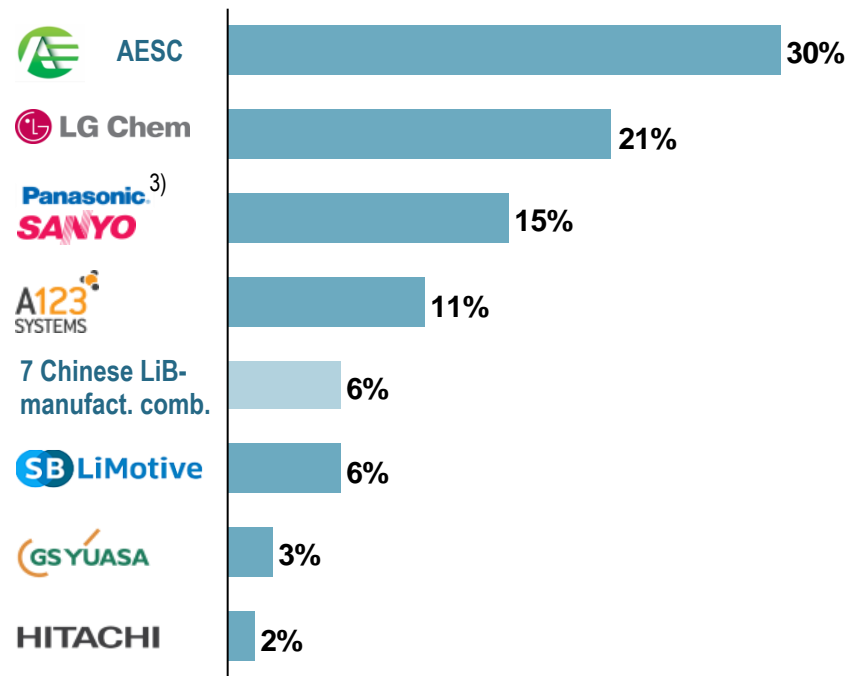

Expected 2015 global market share<sup>1)</sup> [kW, kWh based]

PHEV and EV [kWh]

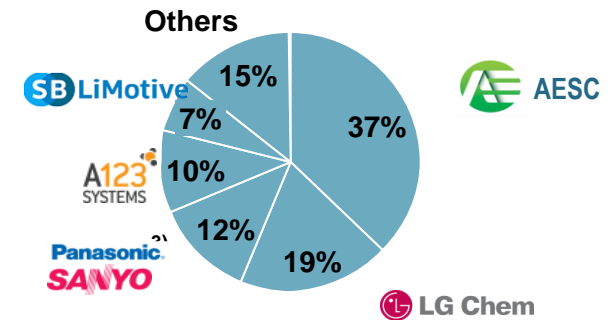

HEV [kW]

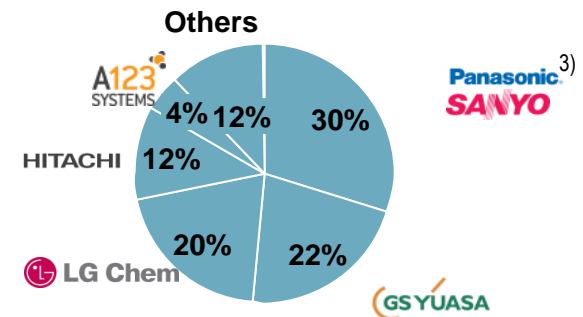

1) Accuracy level: +/- 2%; 2) Market value derived using USD 730/kWh for hybrids, USD 560/kWh for PHEV, and USD 400/kWh for EV in 2015; 3) Includes Primearth's share

# The market shares in light vehicles are heavily dependent on key OEMs meeting their xEV production targets

## 2015 expected light vehicle OEM xEV production and share (LiB only)

### 2015 expected OEM production and share – PHEV/EV<sup>1)</sup>

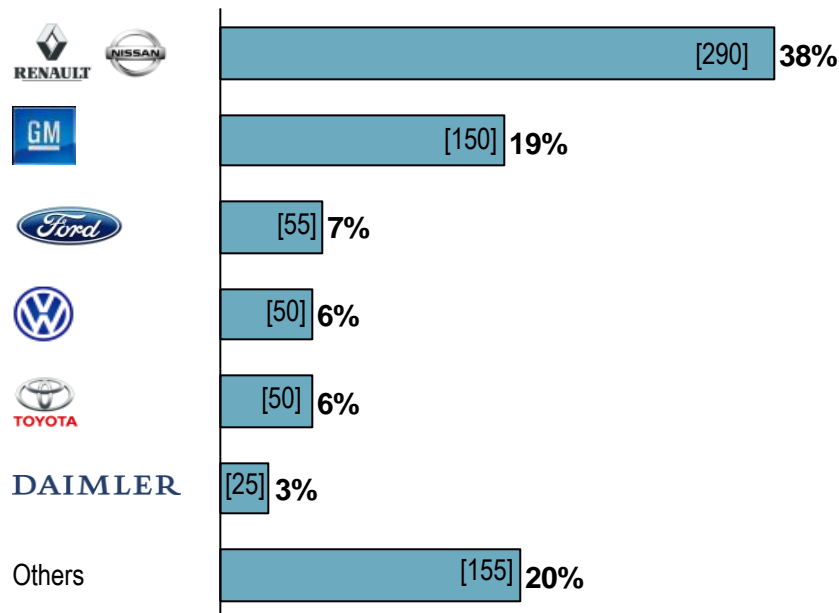

### 2015 expected OEM production and share – HEV<sup>1)</sup>

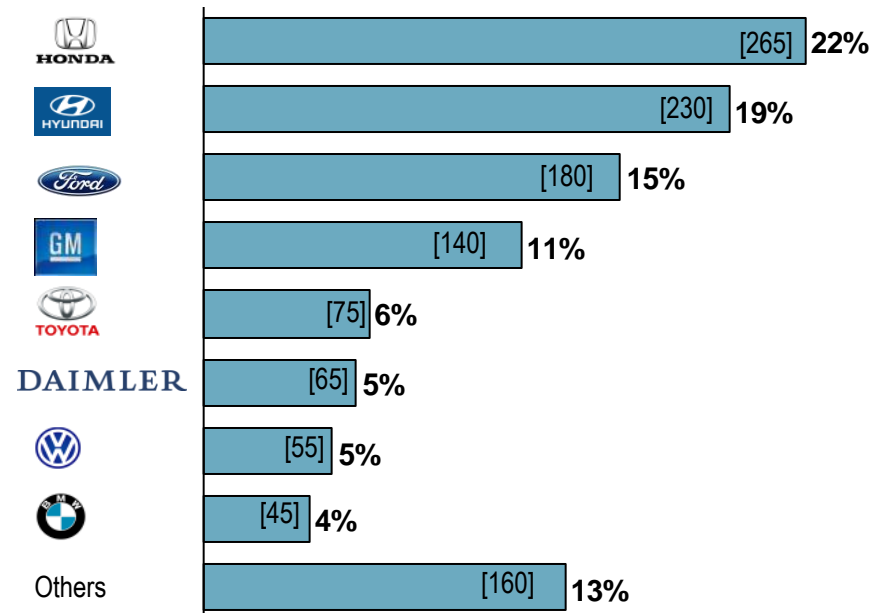

[ xx ] 2015 forecasted production volume ['000s]

1) Share and forecasts are for vehicles with Li Ion batteries

# In trucks and buses, Chinese players have a more important role due to high demand for buses and usage of LiFePo4

## Key industry participants in 2015 (Trucks and buses)

Expected 2015 global market share<sup>1)</sup> [USD based<sup>2)</sup>]

Σ = USD 1.3 bn

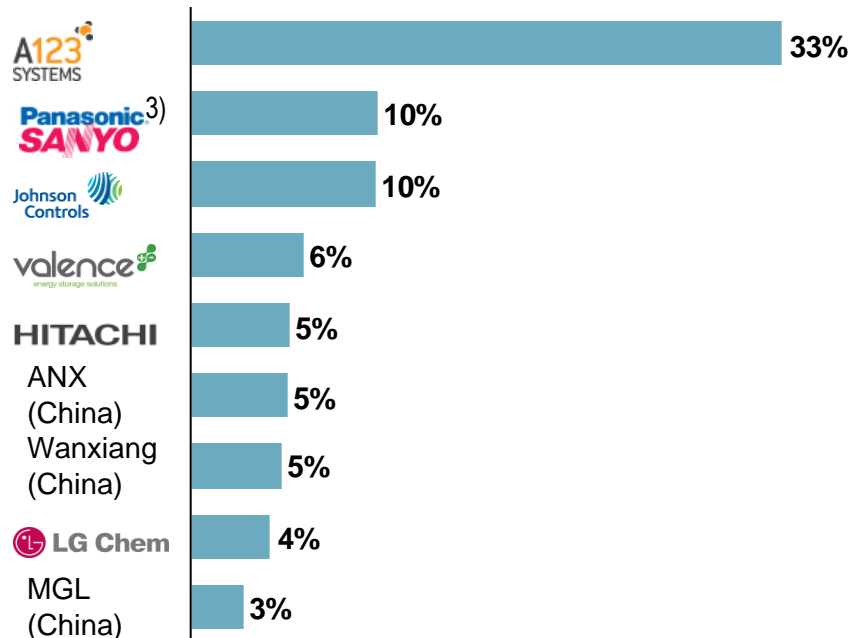

Expected 2015 global market share<sup>1)</sup> [kW, kWh based]

PHEV and EV [kWh]

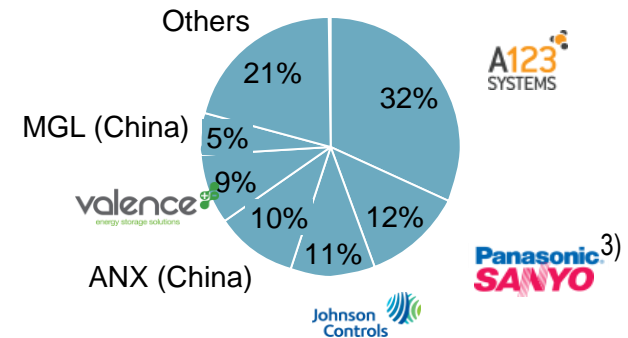

HEV [kW]

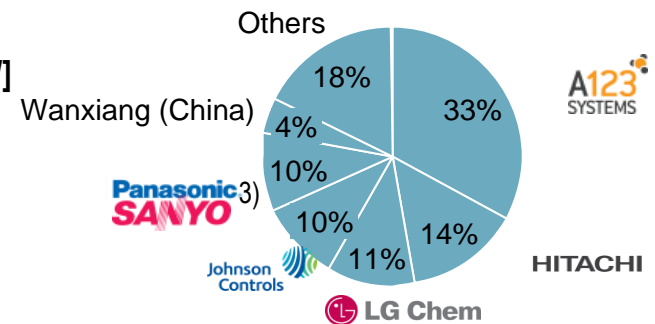

1) Accuracy level: +/- 2%; 2) Market value derived using USD 730/kWh for hybrids, USD 560/kWh for PHEV, and USD 400/kWh for EV in 2015; 3) Includes Primearth's share



# Li-Ion battery still have significant potential in energy density increase – High technology dynamic to be expected

## Li-Ion consumer cell development roadmap

### Specific Energy [Wh/kg]

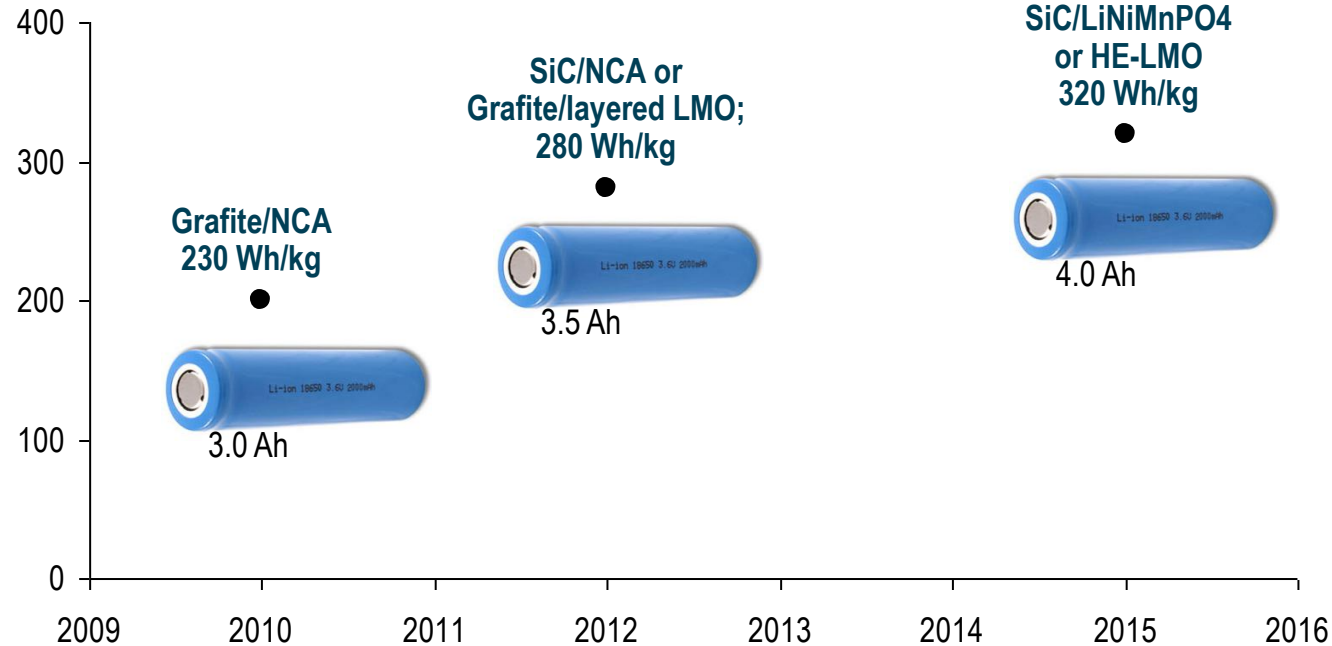

- > Nano structured materials based on silicon and silicon composites for the anode
- > High voltage and high energy layered oxides and/or high voltage phosphates for the cathode
- > Automotive cell development will greatly benefit from consumer with a 3 to 5 year delay!

We expect that in 2025 a specific energy of 240 Wh/kg on pack level could be reached

## Large format Li-Ion-battery development roadmap

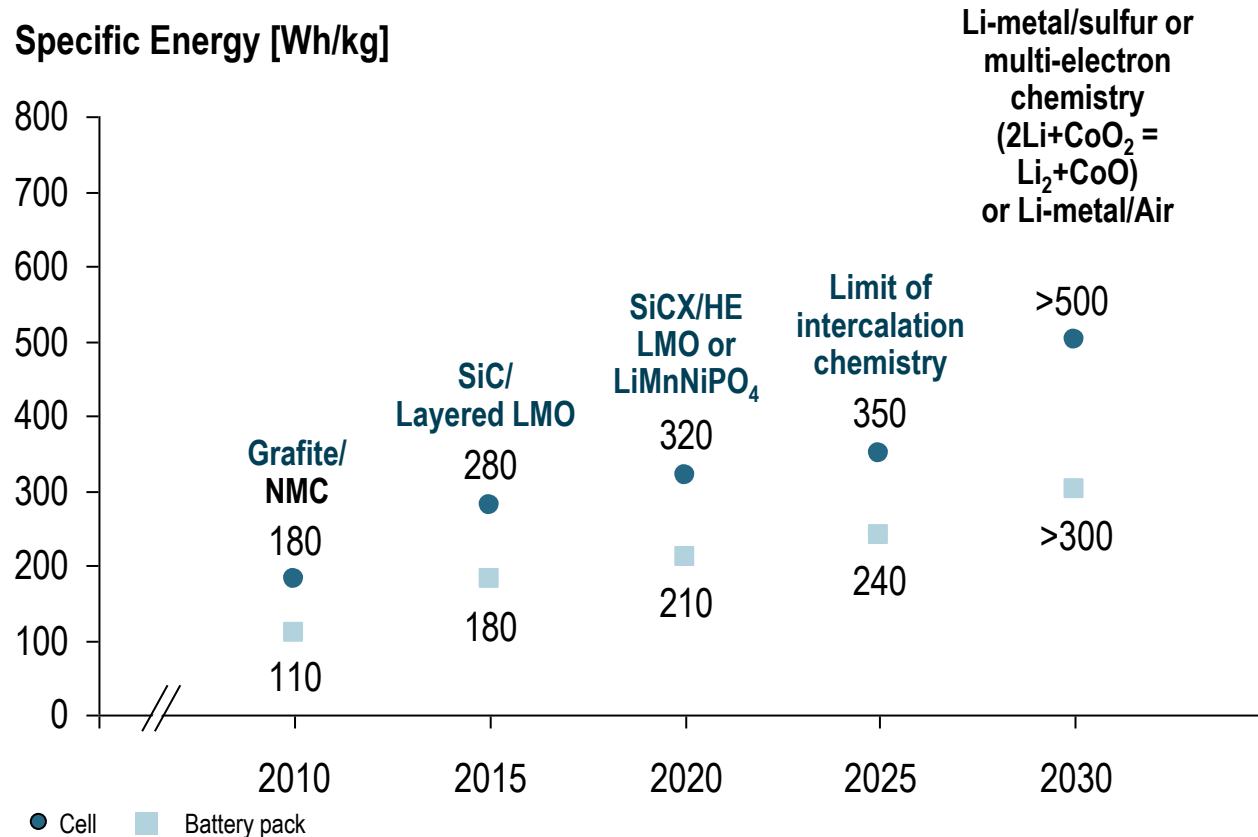

- > The **Li-Ion chemistry** will **dominate** the consumer and automotive markets **for a very long time** due to their high efficiency, long cycle and calendar life, high energy density and manageable safety
- > **Further increase** in energy density is possible **with lithium metal systems**, but **intrinsic problems** with reversibility, cyclability and safety of lithium metal need to be overcome to make lithium metal based systems viable

# Other emerging technologies beyond Lithium-Ion still face significant issues - break-through not foreseeable in next 10..15 years

Battery System	Main Advantages	Disadvantages	Probability of success for EV/PHEV/HEV (%)
Li-metal/Sulfur	Low cost	Low cycle life, safety issues	<50%
Li-metal/Air	Low cost	Low cycle life, low efficiency, safety issues	<30%
Li-Ion/Flow battery (Cambridge Crude)	Separation of energy storage from energy conversion	Pumping of liquids containing dispersed nano particles	Unclear
Li/metal polymer (60 °C)	No liquids	Heating required, low power output, safety issues	<50%
Li-metal/Multi-electron chemistry	High energy density	Low cycle life, low efficiency safety issues	<50%
Sodium/Sulfur (Na/S)	Good cycle life, low cost	Works at 300° C	For large vehicles in fleet applications only
Sodium/Nickel chloride (ZEBRA)	Good cycle life, reasonable cost	Works at 350° C	For large vehicles in fleet applications only
Redox flow batteries	Low cost	Low power output, pumping of liquids	<10%
Sodium and Magnesium ion batteries	Low cost	Low reversibility, low power output	<20%

# The value chain is expected to consolidate and to develop a clearer tiered structure (1/2)

	TODAY (2010)	CHANGES BY 2020
<b>Raw materials Lithium mining</b>	<ul style="list-style-type: none"> <li>&gt; Oligopoly</li> </ul>	<ul style="list-style-type: none"> <li>&gt; Some selected new players</li> <li>&gt; New <b>recycling</b> companies</li> <li>&gt; Business models integrating recycling</li> </ul>
<b>Anodes, Cathodes, Separators, Electrolytes and Precursors</b>	<ul style="list-style-type: none"> <li>&gt; Dominated by Asian (Jap.) players</li> <li>&gt; Partially specialized precursors sourced</li> <li>&gt; Some cathode materials manufactured by cell manufacturer</li> </ul>	<ul style="list-style-type: none"> <li>&gt; <b>New players</b> (from specialty chemical sector ) especially for Automotive and Solar</li> <li>&gt; More <b>integration of precursor</b> manufacturer</li> <li>&gt; Cathode manufacturing by cell manufacturer only for top 2..3 with large chemical business</li> </ul>

# The value chain is expected to consolidate and to develop a clearer tiered structure (2/2)

	<b>TODAY (2010)</b>	<b>CHANGES BY 2020</b>
<b>Battery cells / stacks ("LiB manuf.")</b>	<ul style="list-style-type: none"> <li>&gt; New JVs (Auto-Consumer LiB manuf.)</li> <li>&gt; Indepen. Asian LiB</li> <li>&gt; Research spin-offs with public &amp; IPO funding</li> </ul>	<ul style="list-style-type: none"> <li>&gt; Massive <b>consolidation</b> (cost pressure, innovation)</li> <li>&gt; Less upstream integration (esp. cathode/anode material)</li> <li>&gt; More downstream integration, <b>cell manufacturer as Tier-1s</b> to OEMs</li> <li>&gt; Auto-Cell manuf. <b>JV's as exemption</b></li> </ul>
<b>Battery assembly</b>	<ul style="list-style-type: none"> <li>&gt; Mainly by OEMs (JVs LiB) inhouse</li> <li>&gt; Selected supplier – LiB JVs</li> <li>&gt; Limited LiB alone</li> </ul>	<ul style="list-style-type: none"> <li>&gt; Increased <b>outsourcing</b>, but still <b>dominated</b> by <b>in-house assembly</b></li> <li>&gt; Cell manufacturers will deliver larger part of system (incl. electronics) as Tier-1</li> </ul>

# Agenda

- A MARKET DEVELOPMENT:**  
We expect that by 2020 xEVs sales volume can capture up to 8% .. 10% of global sales, provided battery costs come down
- 
- B CURRENT VALUE CHAIN:**  
Cell manufacturing and processing of active materials represent major parts of current costs – value chain today dominated by Asian players
- 
- C BATTERY COST AND VALUE CHAIN DEVELOPMENT:**  
With battery costs decreasing down to 250 USD/kWh in 2020, the value chain is expected to consolidate and to develop a clearer tiered structure
- 
- D IMPLICATIONS:**  
The Li-Ion-battery value chain will change dramatically, automotive companies need to reflect these dynamics in products, partnering strategies and processes

## The Li-Ion-battery value chain will change dramatically during this decade

- > **Cell costs decreasing rapidly:**  
process and manufacturing technology improvements, improved materials, new competitors
- > **Shake-out of cell producers/consolidation of value chain:**  
6..8 mostly Asian manufacturers likely to serve OEMs as Tier 1's (NEC/AESC, LG Chem, Panasonic/Sanyo, A123, SBlimotive, GSYuasa or Hitachi, likely one/two Chinese )
- > **Li-Ion intercalation chemistries will dominate the market:**  
high technology dynamics to be expected in the next decade

# Auto companies needs to reflect these dynamics in its products, partnering strategies and processes

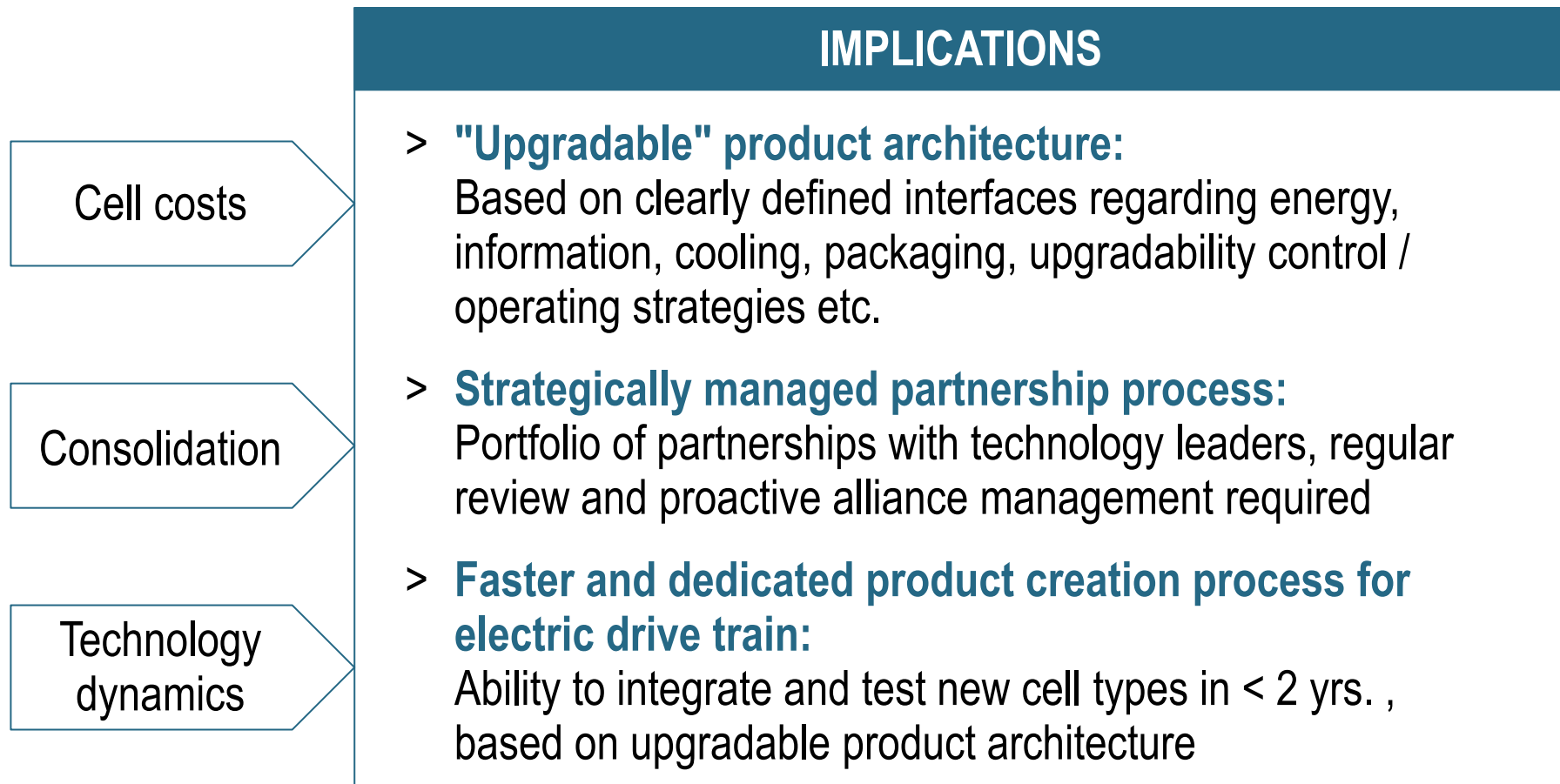

The image shows a close-up, slightly blurred view of a document with the Roland Berger logo. The logo consists of the name "Roland Berger" in a large, bold, blue sans-serif font, with "Strategy Consultants" in a smaller, blue sans-serif font directly below it. The background is a light-colored, textured surface, possibly paper or a folder cover.

**Roland Berger**  
Strategy Consultants

Contact details

Please contact us for further information

**CONTACT**



**Dr. Wolfgang Bernhart**  
Partner

**Roland Berger Strategy Consultants GmbH**  
Automotive Competence Center  
**Loeffelstraße 46**  
**70597 Stuttgart**  
Germany  
Phone +49 711 3275-7421  
Mobile +49 160 744-7421  
[mailto:wolfgang\\_bernhart@de.rolandberger.com](mailto:wolfgang_bernhart@de.rolandberger.com)